

# ICOM<sup>®</sup> INSTRUCTIONS

## DESKTOP CHARGER

# BC-119N

Thank you for purchasing the **BC-119N** DESKTOP CHARGER. The BC-119N charges a Ni-Cd or Ni-MH battery pack in approx. 1-2 hrs., or a Li-Ion battery pack in approx. 2-3 hrs.

Please read these instructions thoroughly before operating the BC-119N.

### CAUTION

⚠ **WARNING!** To reduce the risk of injury, charge only specified Icom Ni-Cd, Ni-MH or Li-Ion rechargeable battery packs. Other types of battery packs/cases may burst, causing damage and personal injury.

⚠ **USE INDOORS ONLY!** NEVER expose the charger to rain, snow or any liquids.

**NEVER** let metal, wire, etc. touch any internal part of the charger.

**NEVER** incinerate used batteries. This may cause an explosion.

**NEVER** use the charger when it is covered by objects which impede heat dispersal.

Place the charger in a secure place to avoid inadvertent use by children.

**AVOID** charging in conditions of extreme cold (under 10°C; +50°F) or extreme heat (over +40°C; +104°F). Batteries may not charge under extreme temperatures.

Keep the charger away from TV sets or radios to prevent interference.

⚠ **NEVER** attempt to charge alkaline or dry cell batteries. They may burst causing damage and personal injury.

▨ Make sure battery and charger contacts are always clean, otherwise batteries may not fully charge.

**SAVE THESE INSTRUCTIONS!** These instructions contain important safety and operating details for the **BC-119N**.

An appropriate desktop charger adapter must be purchased separately to charge your Icom battery packs.

In order to get the maximum life out of your Ni-Cd batteries:

1. Avoid overcharging—batteries must be removed from the charger to stop charging. Batteries should not be charged for more than 15 hours after the LED indicator turns green.
2. Use the batteries until they become almost completely exhausted under normal conditions.

▨ If your batteries seem to have no capacity even after being fully charged, completely discharge them, then fully charge them again. If they still do not retain a charge (or very little), new batteries must be purchased.

#### Information (U.S.A. only)

The Ni-Cd battery that you have purchased is recyclable. At the end of its life, under various state and local laws, it may be illegal to dispose of this battery into the municipal waste stream. Call 1-800-822-8837 for battery recycling options in your area or contact your dealer.



Some versions of the BC-119N which display the "CE" symbol on the serial number comply with the essential requirements of the 89/336/EEC directive for Electromagnetic Compatibility.

This compliance is based upon the harmonised CENELEC generic standard EN50 081-1: 1992 and EN50 082-1: 1991.

### ATTACHING A DESKTOP CHARGER ADAPTER

There are 2 desktop charger adapter types for the BC-119N. One has a PCB, the other does not. The non-PCB types require an additional PCB (AD-75 or AD-88). For some versions, the AD-75 or AD-88 is already installed in the BC-119N.

◆ **For types requiring the AD-75/AD-88:** Install the optional AD-75 or AD-88 to the BC-119N with 4 screws (supplied with the AD-75/AD-88), then attach a desktop charger adapter to the BC-119N. See the transceiver's instruction manual for an approved desktop charger adapter.

#### ◆ For the PCB types:

Connect the plugs of an appropriate desktop charger adapter and the BC-119N, then installed the adapter with the screws (supplied with the adapter). For some versions, the desktop charger adapter is already installed.

#### • Installing the PCB type adapter

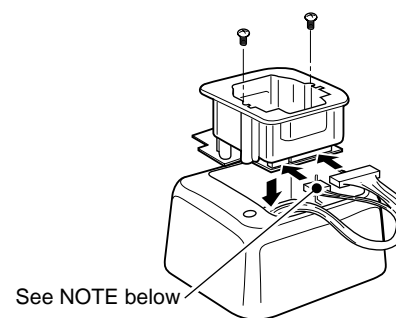

▨ **NOTE:** Some of the PCB type desktop charger adapters (incl. AD-75/88) do not need connection of the 3-pin connector. The connection is required only for the installing adapter that is compatible with charging a Li-Ion battery pack.

#### • Installing the AD-75/AD-88

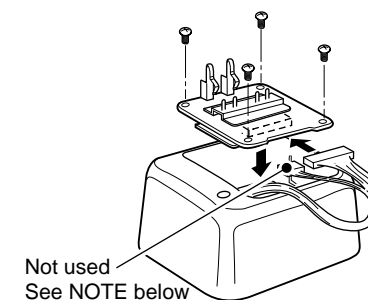

#### • Installing the non-PCB type adapter

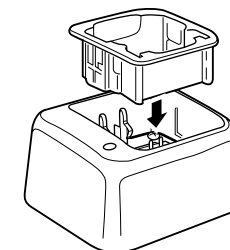

#### ⚠ CAUTION About the 3-pin connector:

When you replace the desktop charger adapter from the Li-Ion compatible type to non-compatible type, fix the 3-pin connector to the bottom of the charger with adhesive tape, etc., to prevent catching or touching the 3-pin connector's terminals with the adapter's leads, etc.

Fix the connector with adhesive tape, etc.

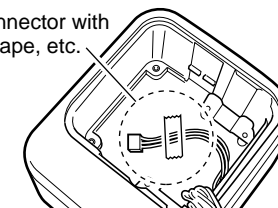

Icom, Icom Inc. and ICOM are registered trademarks of Icom Incorporated (Japan) in the United States, United Kingdom, Germany, France, Spain, Russia and/or other countries.

Icom Inc.

1-1-32 Kamiminami, Hirano-ku, Osaka 547-0003 Japan

Count on us!

A-6099D-1EX-1 Printed in Japan  
© 2001 Icom Inc.

## CHARGING OPERATION

### • Charging example— AD-102 for IC-M1V/M1EURO V

#### CAUTION

- The transceiver power **MUST** be turned **OFF** during charging otherwise;
- The battery will not be charged correctly.
  - The battery life may be shortened.
- The transceiver cannot be used even when the power is ON.*

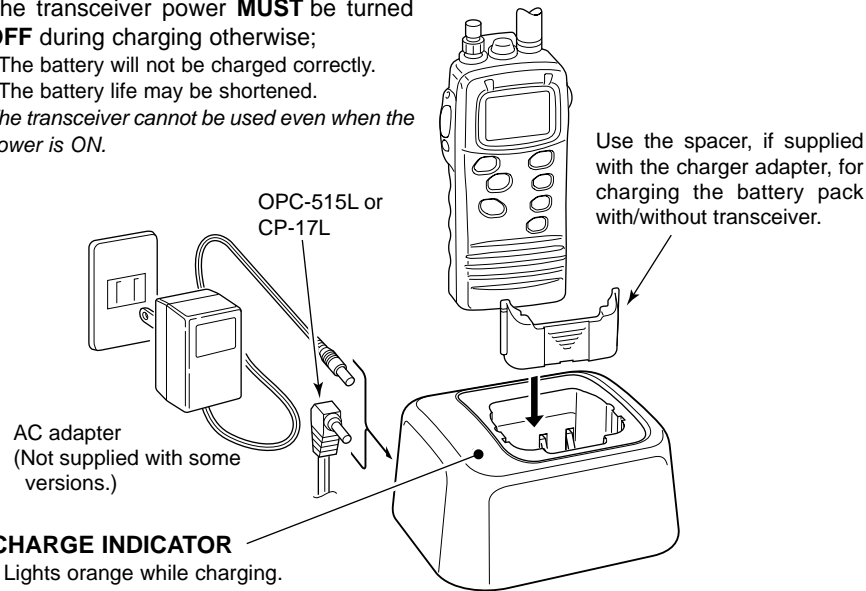

#### CHARGE INDICATOR

- Lights orange while charging.
- Lights green when rapid charging is completed.
  - But it is still charging in trickle charge mode when charging Ni-Cd or Ni-MH battery pack.
- Flashes red when the protection circuit is activated.
  - Check the power source (voltage) or re-connect the power plug.
  - The battery temperature is outside of the charging range. (Ni-MH battery only)

#### NOTE for Ni-Cd/Ni-MH battery packs:

The BC-119N rapidly charges a battery pack to a specified level, not a completed level, to prevent over-charging. Leave the battery pack in the charger for a few more hours (up to 15 hours; depending on battery condition) after the LED indicator turns green, to charge the battery completely.

#### Recommendation for Li-Ion battery packs:

Li-Ion batteries are different from Ni-Cd batteries in that it is not necessary to completely charge and discharge them to prolong the battery life. Therefore, charging the battery in intervals, and not for extended periods is recommended.

## DESKTOP CHARGER ADAPTERS

### ◇ PCB type adapters

Transceiver	Charger Adapter	Battery pack
IC-F10/F20, IC-M10A/E, IC-2GX series, IC-V68/U68	AD-66	BP-157/A, BP-160/R, BP-174
IC-F30/F40, IC-F35/F45	AD-67*	CM-140/141/142*
IC-M15, IC-GM1500	AD-68	CM-138/139/165
IC-M1, IC-M1EURO	AD-69	BP-185/186
IC-F3/F4/S, IC-T2H/A/E, IC-F4SR/TR, IC-A4, IC-40S	AD-81	BP-195/196/R
IC-4008A/E/M, IC-4008MKII, IC-446S, IC-40Jr	AD-89	BP-202
IC-F30G/F40G, IC-F3G/F4G, IC-F11/F21/F12/F22, IC-V8, IC-T3H	AD-94*	BP-209/210*/222
IC-F30G/F40G, IC-F3G/F4G, IC-F11/F21/F12/F22, IC-V8, IC-T3H	AD-101**†	BP-209/210*/211†, BP-222
IC-M1V, IC-M1EURO V	AD-102†	BP-215†

### ◇ Non-PCB type adapters (AD-75 or AD-88 is required)

Transceiver	Charger Adapter	Battery pack
IC-W21/X21, IC-2GX series	AD-28 +AD-75	BP-131/132/157/A, BP-160/174
IC-A3/A22	AD-50 +AD-75	CM-166
IC-Z1A/E, IC-W31/W32	AD-51 +AD-75	BP-171/172/173, BP-180
IC-T22/T42, IC-T7A/E/H	AD-56 +AD-75	BP-171/172/173, BP-180
IC-T8, IC-T81, IC-A5/A23	AD-87 +AD-88*	BP-198*/199*/200*/L*

\*AD-67, AD-88, AD-94 and AD-101 have a temperature detection circuit for the Ni-MH battery. When the battery's temperature is outside the charging range, charging stops and the charging indicator flashes until the temperature returns to within the range.

†AD-101 and AD-102 are compatible for charging the Li-Ion battery packs, BP-211 and BP-215, respectively.

The BC-119N may be able to be used with future transceivers not listed above. See the transceiver instruction manual for the appropriate adapter information.

## SPECIFICATIONS

**Dimensions** : 115(W)×103(D)×60(H) mm  
(proj. not incl.)  
4½(W)×4¼(D)×2¼(H) in.

**Weight** : 200 g; 7.1 oz

**Charging temperature range:**  
10°C to 40°C; +50°F to +104°F

**Power supply requirement:**  
12 to 20 V DC or the specified Icom AC adapter (BC-145)

**Charging current** : 420 mA±10% (rapid charging)  
540 mA±10% (rapid charging)  
670 mA±10% (rapid charging)  
840 mA±10% (rapid charging)  
30 mA±10 mA (trickle charging)

**Electrostatic durability:**  
Air discharge 8 kV  
Contact discharge 4 kV